

Pressure-regulator of the Standard series

Pressure regulator G1/2 pneumatic pilot operated (G1/4)

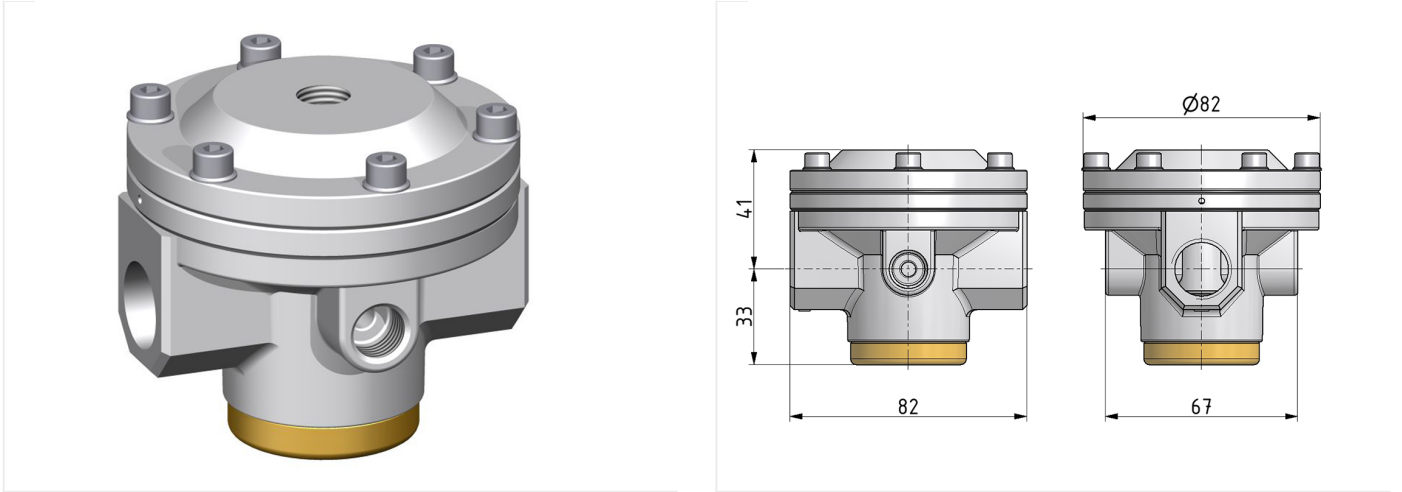

type	part-number	series	port size	flow rate	adjustment range P2 max.	weight
DRI.33	9.1533.00.100.0V	Standard	G 1/2	5800 l/min	16 bar	0.841 kg

flow characteristic

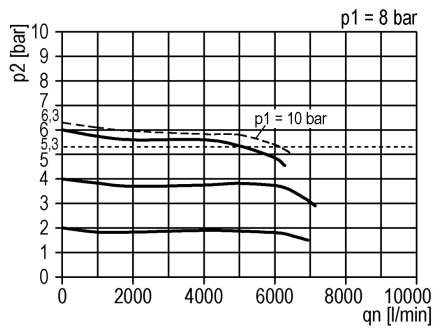

operating conditions

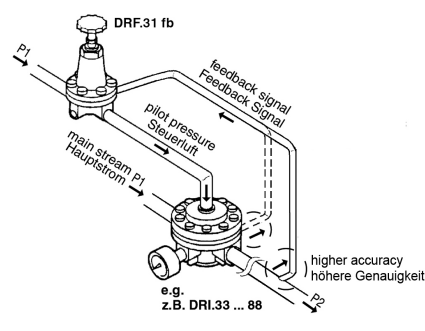

exhaust characteristics

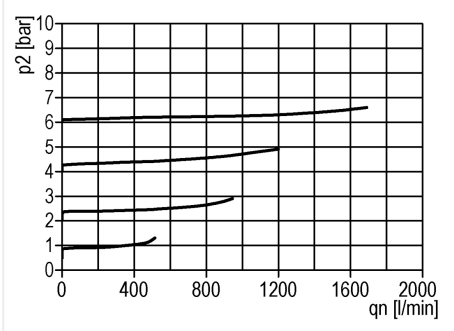

pressure characteristic

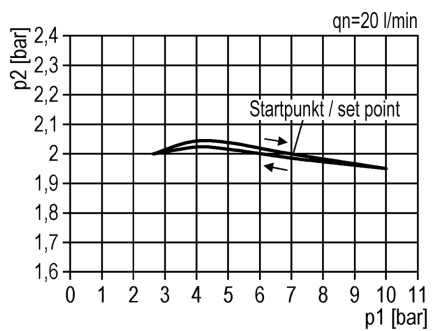

symbol

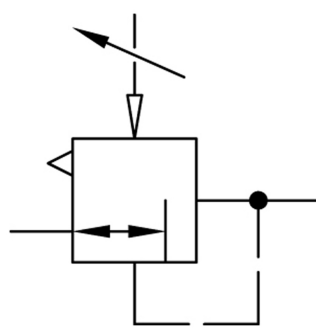

technical data

- **description:** air line regulator with diaphragm and relieving feature, pneumatic pilot-operated (1:1)
- **medium:** compressed air, neutral gases
- **supply pressure P1 max.:** 25 bar
- **temperature range:** -10°C - +80°C

accessories

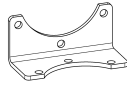

- mounting bracket: [BW.30](#)