

Pressure-regulator of the Standard series

Pressure regulator G2 0,5-10 pilot control with gauge G 50.25 R and G 50.16 R

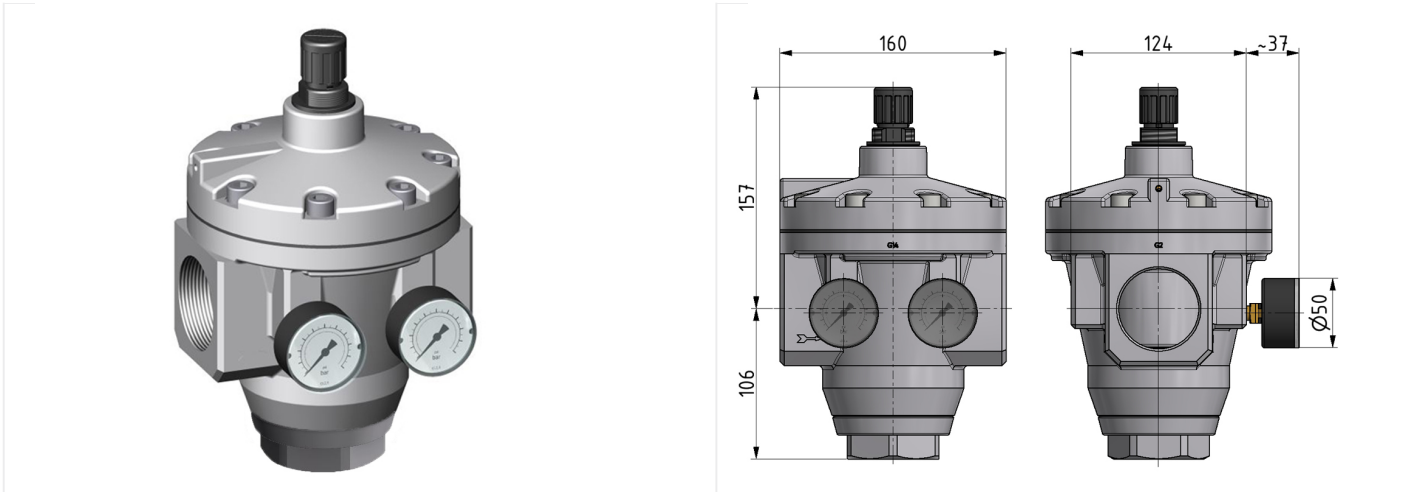

type	part-number	series	port size	flow rate	adjustment range P2 max.	weight
DRP.88 G	9.1588.00.202.0V	Standard	G 2	50000 l/min	10 bar	5.806 kg

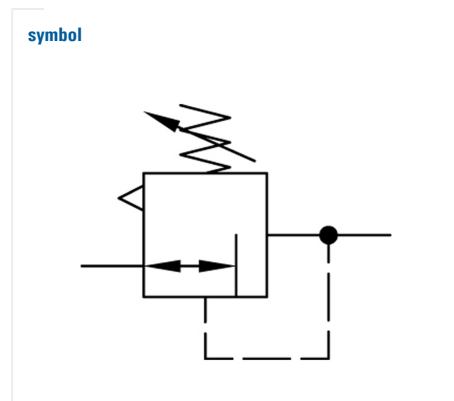
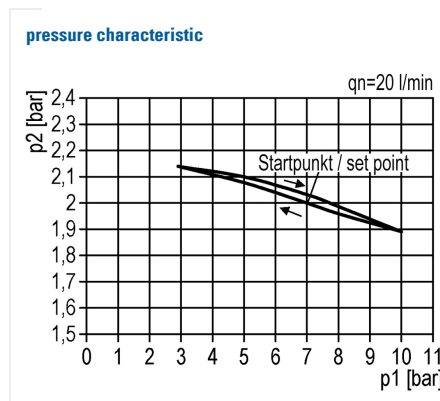
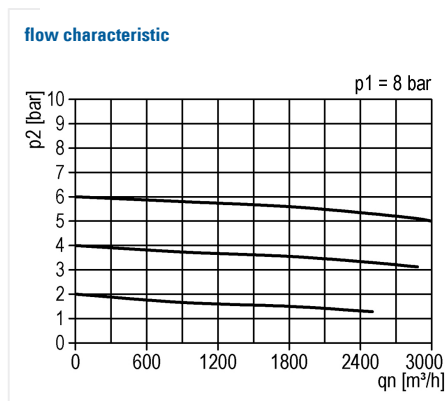

technical data

- **description:** air line regulator with diaphragm and relieving feature, pilot operated
- **medium:** compressed air, neutral gases
- **supply pressure P1 max.:** 25 bar
- **temperature range:** -10°C - +60°C

accessories

- lockable setting knob possible