

## Pressure-regulator of the Standard series

Pressure regulator G3/8 0,5-10 with gauge G 50.16 R

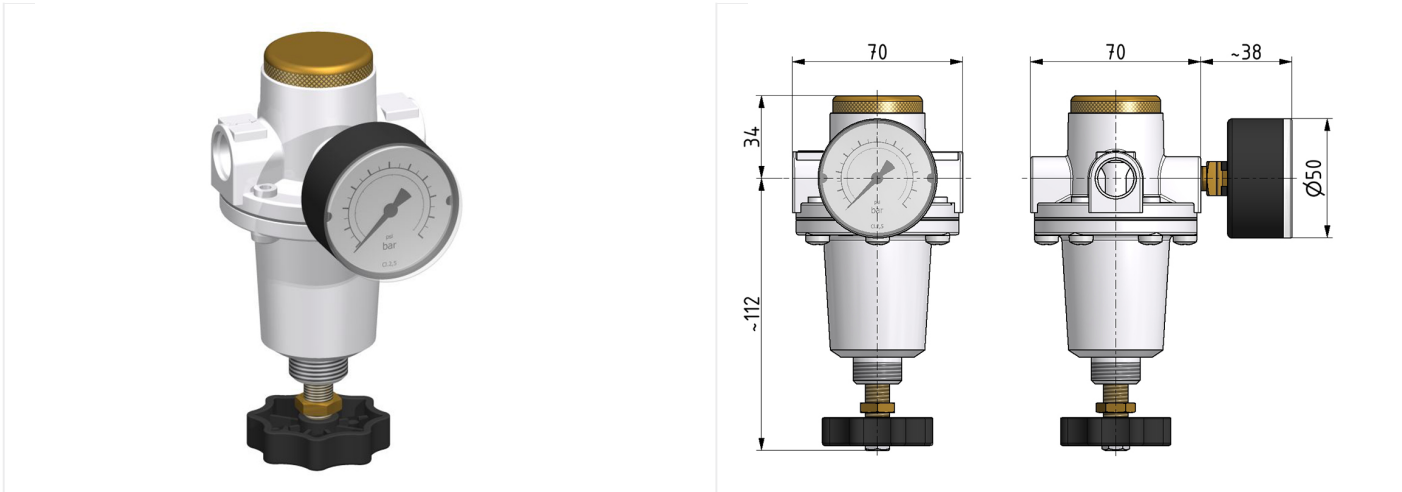

type	part-number	series	port size	flow rate	adjustment range P2 max.	weight
DR.22 G	9.1522.00.002.0V	Standard	G 3/8	2200 l/min	10 bar	0.845 kg

flow characteristic

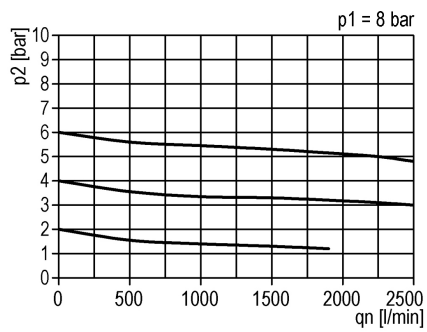

pressure characteristic

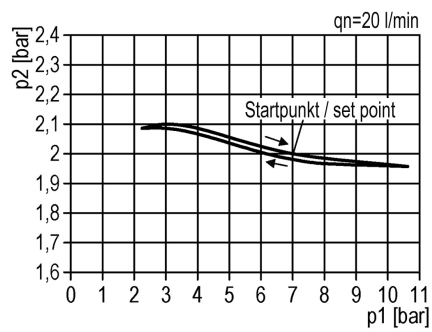

symbol

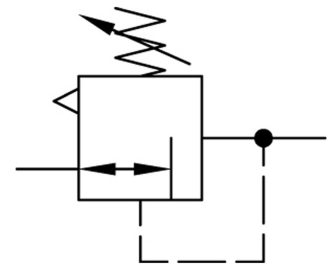

**technical data**

- **description:** air line regulator with diaphragm and relieving feature
- **medium:** compressed air, neutral gases
- **supply pressure P1 max.:** 25 bar
- **temperature range:** -10°C - +60°C

**accessories**

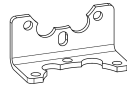

- mounting bracket: [BW.20](#)

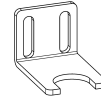

- control panel mounting:  
[WH.M 20/DR.11-7](#)