

Pressure-regulator of the Standard series

Pressure regulator G1/2 0,5-10 with gauge G 63.16 R

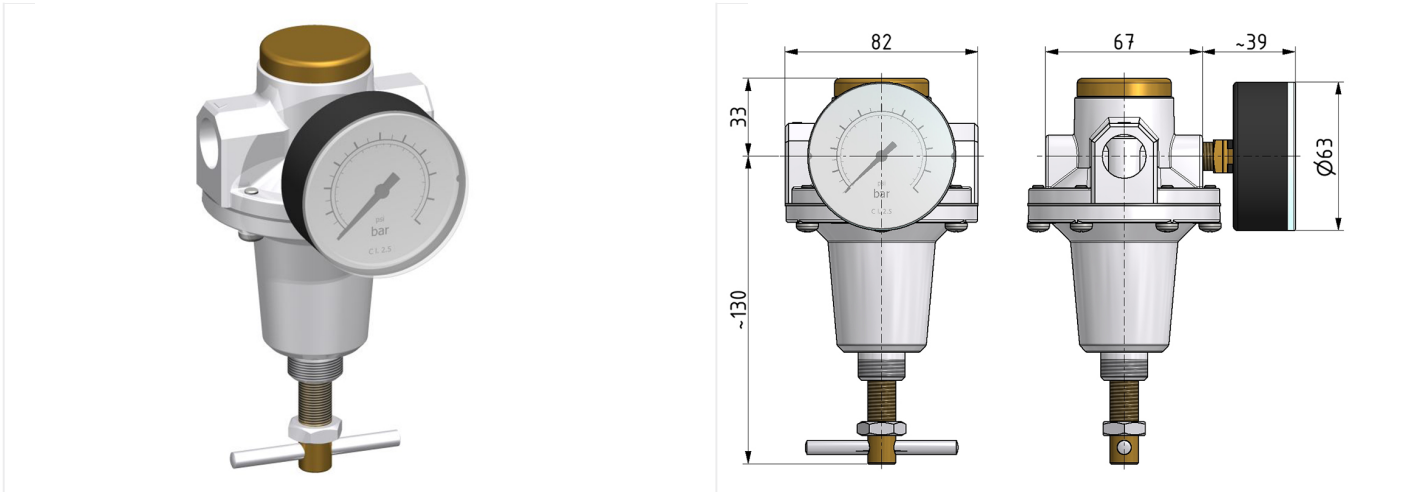

type	part-number	series	port size	flow rate	adjustment range P2 max.	weight
DR.33 G	9.1533.00.002.0V	Standard	G 1/2	5000 l/min	10 bar	1.200 kg

flow characteristic

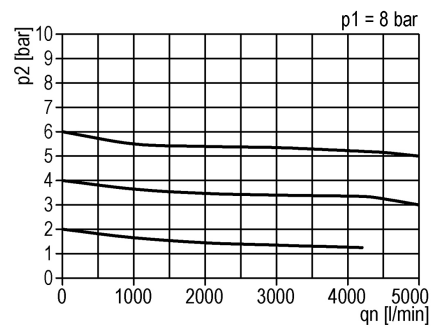

pressure characteristic

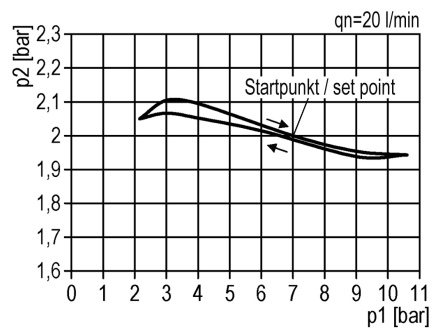

symbol

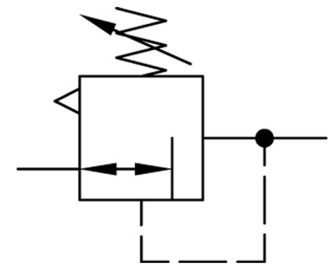

technical data

- **description:** air line regulator with diaphragm and relieving feature
- **medium:** compressed air, neutral gases
- **supply pressure P1 max.:** 25 bar
- **temperature range:** -10°C - +60°C

accessories

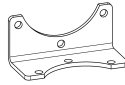

- mounting bracket: [BW.30](#)
- control panel mounting: nut DR.11-7