

## Accessories of the Standard series

Bracket galvanized and nut M30x1,5

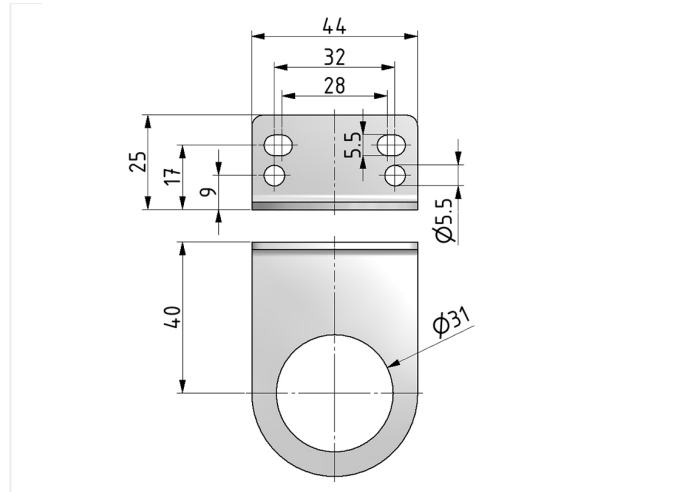
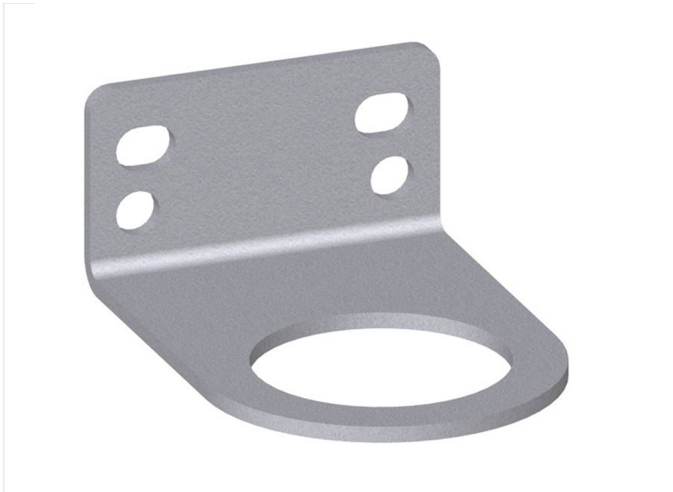

type	part-number	series	series	weight
WH.M 30/DR.00-34	9.9911.00.024	Standard	BG0	0.052 kg

### technical data

- **description:** Mounting bracket for panel mounting
- **material:** steel galvanized
- **fixing:** control panel nut and 2 screws for fixation to wall

### accessories