

HOLLE ZUIGERSTANG CILINDER

SERIE

H

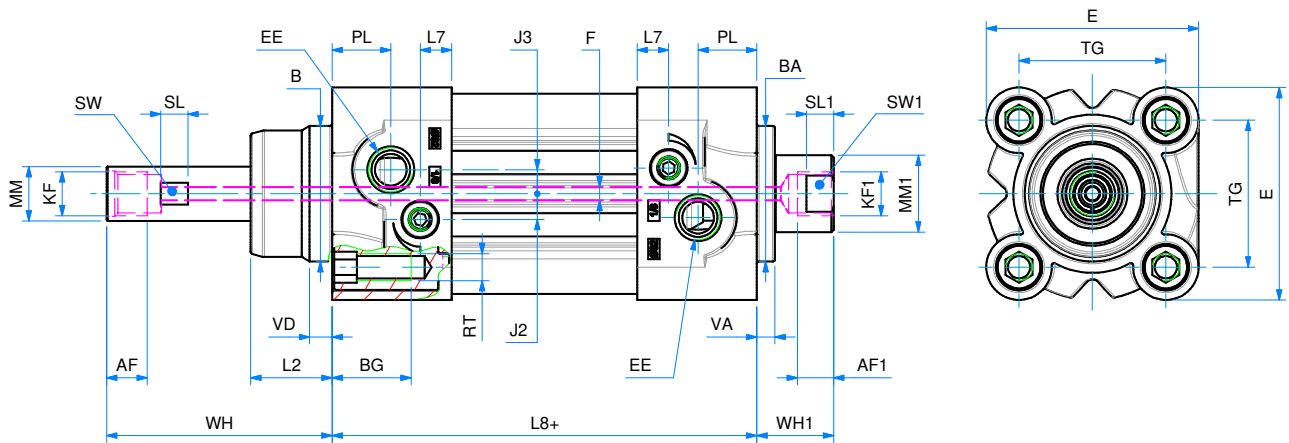

DIAMETER

	032	040	050	063
AF	7,5	9	12	12
AF1	7,5	12	12	12
ø B	30	35	40	45
ø BA	30	35	40	45
BG	16	16	16	16
E	47	54,5	65	75
EE	G1/8"	G1/4"	G1/4"	G3/8"
F	3	7	7	7
J3	5,3	5	6	7,5
KF	G1/8"	G1/4"	G3/8"	G3/8"
KF1	G1/8"	G1/4"	G1/4"	G1/4"
L2	18	22	25,5	26
L8+	94	105	106	121
ø MM	12	16	20	20
ø MM1	17	20	20	20
PL	13	14	14	16
RT	M6	M6	M8	M8
SL	6	7	8	8
SL1	6	6	6	6
SW	11	14	18	18
SW1	15	18	18	18
TG	32,5	38	46,5	56,5
VA	4	4	4	4
VD	5	5	6	6
WH	50	40	41	41
WH1	17,5	19	19	19

ø SLAGLENGTE

032	50 - 100 - 150 - 200 - 250 - 300 - 350
040	50 - 100 - 150 - 200 - 250 - 300 - 350
050	50 - 100 - 150 - 200 - 250 - 300 - 350
063	50 - 100 - 150 - 200 - 250 - 300 - 350

+ = **SLAGLENGTE**