

TECHNICAL CATALOGUE

FULL FLOW BALL VALVES: IDEAL

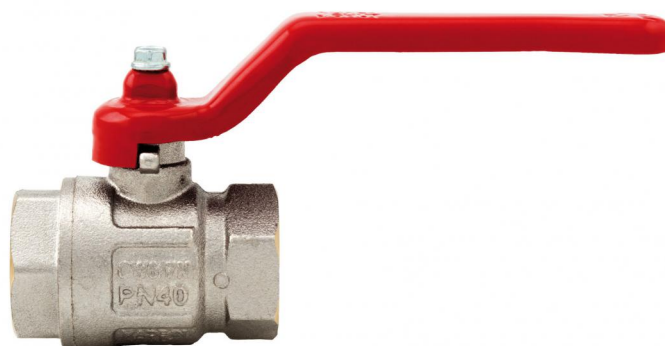

> THE COMPANY

ITAP SpA, founded in Lumezzane (Brescia) in 1972, is currently one of the leading production companies in Italy of **valves, fittings and distribution manifolds** for plumbing and heating systems.

Thanks to fully automated production processes, with 87 transfer machines and 70 assembly lines, we are able to produce 400,000 pieces per day.

Our innate pursuit for innovation and observance of technical regulations is supported by the company certification ISO 9001. The company has always considered its focus on quality as the main tool to obtain significant business results: today ITAP SpA is proud to offer products bearing the approval of numerous international certifying bodies.

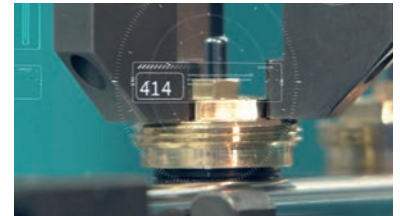

> ITAP products have obtained approvals by more than 30 certification bodies from all over the world.





FULL FLOW BALL VALVES: IDEAL

090 Ideal ball valve, full flow

Suitable for domestic water services, heating and air-conditioning plants, compressed air systems.

IDEAL



SIZE	PRESSURE	CODE	PACKING
1/4" (DN 8)	50bar/725psi	0900014/N	12/168
3/8" (DN 10)	50bar/725psi	0900038/N	12/168
1/2" (DN 15)	50bar/725psi	0900012/N	12/132
3/4" (DN 20)	40bar/580psi	0900034/N	8/56
1" (DN 25)	40bar/580psi	0900100/N	8/48
1"1/4 (DN 32)	30bar/435psi	0900114/N	4/24
1"1/2 (DN 40)	30bar/435psi	0900112/N	2/14
2" (DN 50)	25bar/362.5psi	0900200/N	2/10
2"1/2 (DN 65)	18bar/261psi	0900212/N	1/7
3" (DN 80)	16bar/232psi	0900300/N	1/4
4" (DN 100)	14bar/203psi	0900400/N	1/2

CERTIFICATIONS

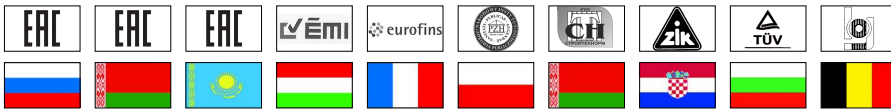

TECHNICAL SPECIFICATIONS

Female/female threads.

Lever handle in steel (aluminium in the sizes 2"1/2, 3" and 4").

Body in nickel-plated brass.

Minimum and maximum working temperatures: -20°C, 150°C in absence of steam.

Threads: ISO 228 (equivalent to DIN EN ISO 228 and BS EN ISO 228).

Mention "N" in the code only to order the black handle.

Available also with NPT thread in the sizes 1/4" through 2".



FULL FLOW BALL VALVES: IDEAL

OVERALL DIMENSIONS

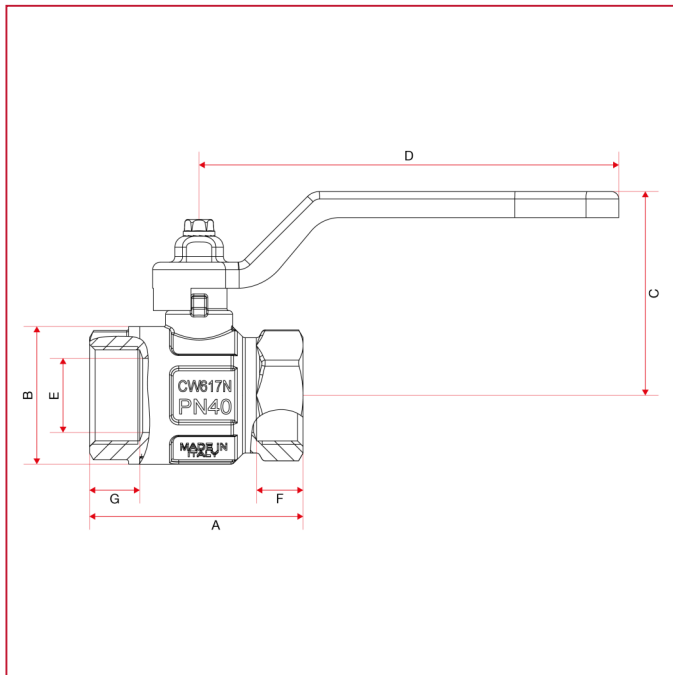

	1/4"	3/8"	1/2"	3/4"	1"	1"1/4	1"1/2	2"	2"1/2	3"	4"
DN	8	10	15	20	25	32	40	50	65	80	100
A	44,4	44,4	50,5	57,5	70	80,5	94,5	112,5	134,5	157	190
B	23,5	24	30,5	37	45,5	57	70	84	109	131	164
C	37	37	41	55	59	75	81	96	115	133	149
D	80	80	80	113	113	138	138	157,8	197	250	250
E	10	10	15	20	25	32	40	50	65	80	100
F	10	10	12	12,5	15	17	18,5	22	24	26	30
G	10	10	12,5	13,5	15	16,5	17,5	20,5	24	26	30
Kg/cm ² bar	50	50	50	40	40	30	30	25	18	16	14
LBS - psi	725	725	725	580	580	435	435	362,5	261	232	203



FULL FLOW BALL VALVES: IDEAL

MATERIALS sizes 1/4" through 2"

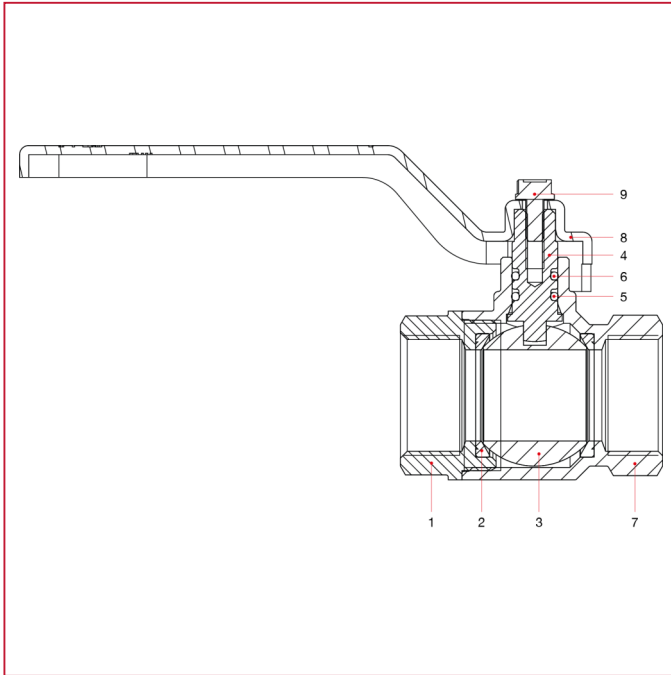

POS.	DESCRIPTION	N.	MATERIAL
1	Female end adapter	1	Nickel-plated brass CW617N
2	Seat	2	P.T.F.E.
3	Ball	1	Chrome-plated brass CW617N
4	Stem	1	Brass CW614N
5	O-ring	1	NBR
6	O-ring	1	Viton®
7	Body	1	Nickel-plated brass CW617N
8	Lever handle	1	Varnished steel P04
9	Screw	1	Zinc-plated steel C4C



FULL FLOW BALL VALVES: IDEAL

MATERIALS sizes 2"1/2 through 4"

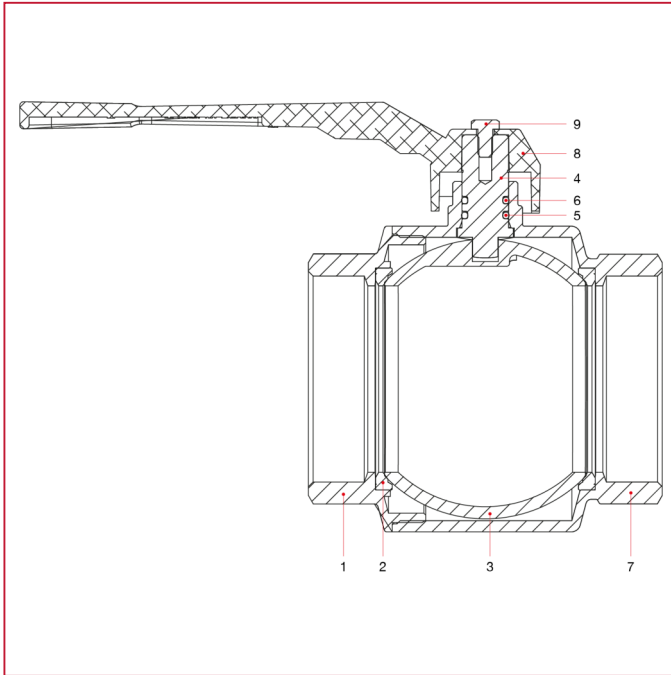

POS.	DESCRIPTION	N.	MATERIAL
1	Female end adapter	1	Nickel-plated brass CW617N
2	Seat	2	P.T.F.E.
3	Ball	1	Chrome-plated brass CW617N
4	Stem	1	Brass CW614N
5	O-ring	1	NBR
6	O-ring	1	Viton®
7	Body	1	Nickel-plated brass CW617N
8	Lever handle	1	Varnished aluminium
9	Screw	1	Zinc-plated CB4 FF (C34)



FULL FLOW BALL VALVES: IDEAL

INSTALLATION

The Itap S.p.A.'s valves are bi-directional, that means they manage the flow in both the directions.

The valves are composed by a ball, two seal in PTFE material, one stem, two sailing rings (O-Rings), one handle and a couple of parts made of brass (body and end adapter) that contain them and that are assembled by means of thread and a sealed material to obtain their aim.

In order to avoid that the sealed material gets broken and then the valve loses the connection between the body and the end-adapter, it's necessary to avoid to submit the two parts under the influence of a torque.

For the installation normal hydraulic practices must be used, and especially:

- ones have to be sure that the two pipes are correctly aligned;
- during the assembling process the installer has to apply its assembling tools at the end that is nearest to the pipe;
- the application of the sealing materials by the fitter (PTFE or hempen cloth) must be limited at the thread zone. An excess should interfere in the ball-gasket's closure zone, compromising the tightness.
- in the case that the fluid transported presents some impurities (dust, water too hard, etc.) ones have to remove these impurities by the means of a filter. Otherwise they could damage the seals.

DISASSEMBLY

To remove the valve from the pipe line or anyhow before to unscrew the junctions linked to it:

- wear the clothing protective normally required to work with the fluid transported within the line;
- depressurize the line and operate in this way:
 - positioning the valve in opened position and then empty the line;
 - handle the valve to put down the residue pressure contained inside the space between the ball and the body before of remove it from the line;
- during the disassembly apply the screw tool at the end of the valve nearest the pipe;

MAINTENANCE

Verify the valve periodically, according to its application's field and its works' field and its work's conditions, in order to be sure that the valve works correctly.



FULL FLOW BALL VALVES: IDEAL

LOSS DIAGRAM (With water)

	1/4"	3/8"	1/2"	3/4"	1"	1"1/4"	1"1/2"	2"	2"1/2"	3"	4"
KV	3,45	5,00	15,65	26,26	41,44	63,69	101	169	348	390	725

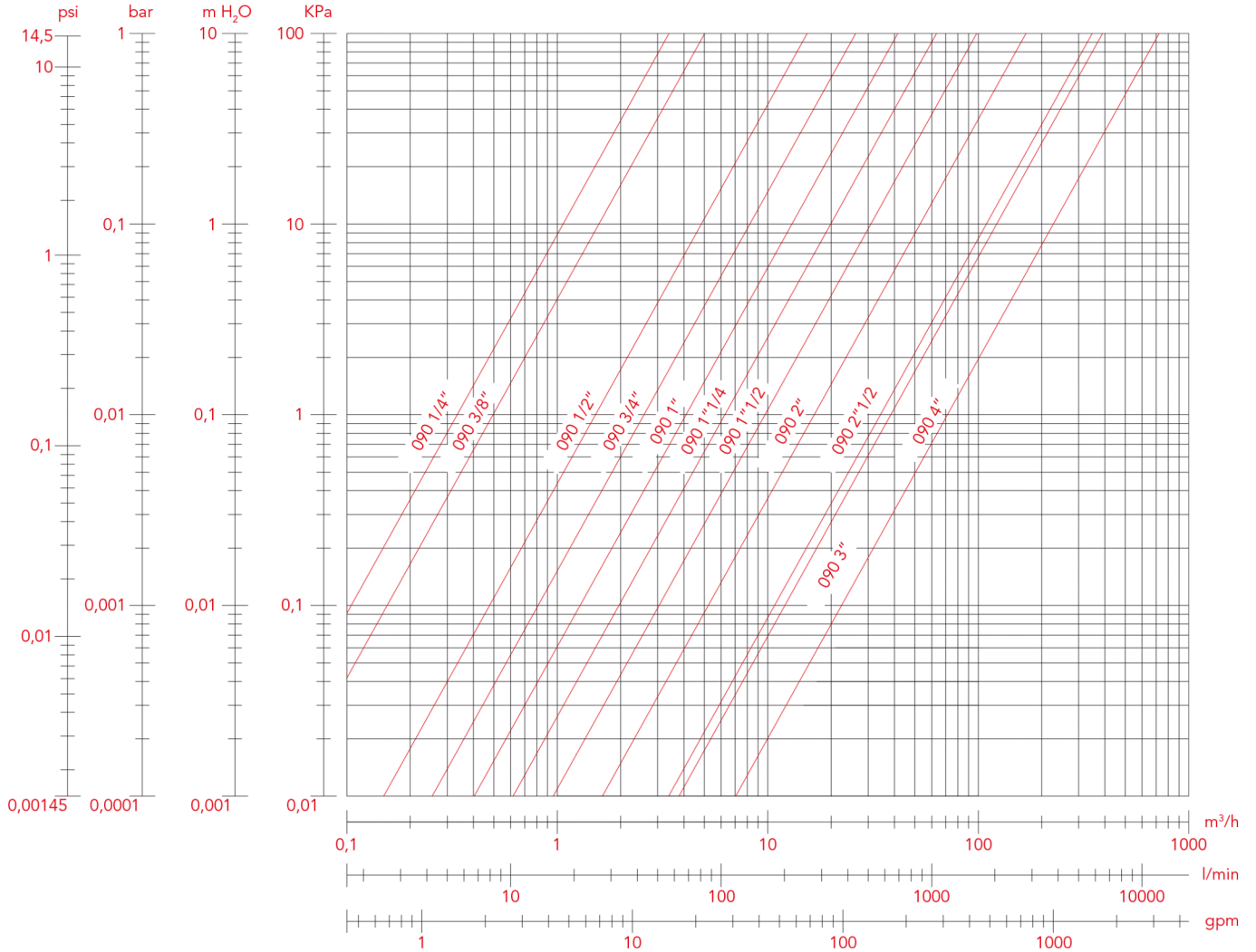



FULL FLOW BALL VALVES: IDEAL

PRESSURE-TEMPERATURE DIAGRAM

The values shown by the dropping lines state the maximum limit of employment of the valves.
The shown values are approximate.

